

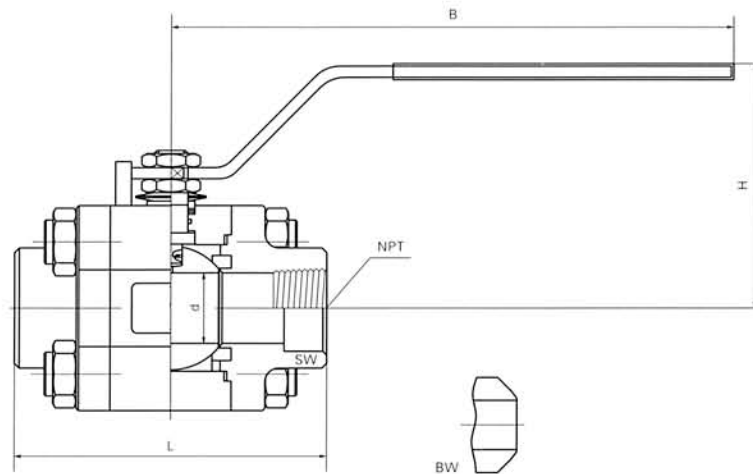

Fumagalli S.p.A
Milano - Roma - Italy

3PCS Forged Steel Ball Valves

V A L V E S



CL800-CL1500

Connection ends may be pipe-welded (butt-welding or socket welding) and/or threaded, design to BS5351

Specification(NPS)	F.P	1/4	3/8	1/2	3/4	1	1 1/4	1 1/2	2	
Face to face	L	92	92	92	111	127	140	152	152	
Center to handle end	B	108	108	108	146	178	178	200	200	
Height	H	51	51	51	108	81	85	105	105	
Height(angle dimension)	d	CL800	6	9	13	18	23	28	35	49
	CL1500	6	9	13	19	25	32	38	49	
Weight(Kg)		2.5	2.4	2.3	3.4	5.4	6.4	11	13	
		2.5	2.4	2.5	3.7	5.8	6.8	11.5	13.7	

CL2500

Connection ends may be pipe-welded (butt-welding or socket welding) and/or threaded, design to BS5351

Specification(NPS)	F.P	1/4	3/8	1/2	3/4	1	1 1/4	1 1/2	2
Face to face	L			110	125	135		160	
Center to handle end	B			170	230	230		310	
Height	H			95	110	125			
Height(angle dimension)	d			13	19	25		38	
Weight(Kg)				2.7	4.1	6.3		12	



Fumagalli S.p.A

Milano - Roma - Italy

V A L V E S

3PCS Forged Steel Ball Valves

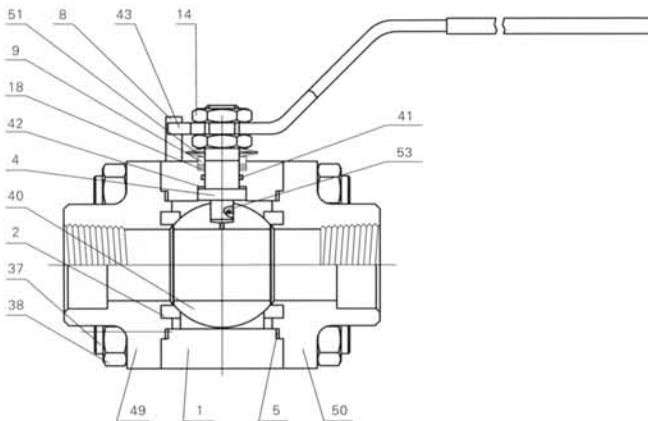

Application standards

- 1、 Design and manufacture conform to BS5351 MSS SP-118;
- 2、 Connection ends conform to:
 - 1)Socket welded ends conform to ANSI B16.11;JB/T1751
 - 2)Screw ends conform to ANSI B1.20.1;JB/T7306
 - 3)Butt-welded ends conform to ANSI B16.25;JB/T12224
 - 4)Flanged ends conform to ANSI B16.5;JB79
- 3、 Test and inspection conform to: API 598; GB/T13927; JB/T9092
- 4、 Structure features: Bolted bonnet; three-piece;
- 5、 Materials conform to ANSI/ASTM.
- 6、 Main materials: A105; LF2; F5; F11; F22; 304(L); 316(L); F347; F321; F51; Monel; 20 Alloy.

Carbon steel temperature-pressure rate

CL150-285 P.S.I @ 100° F
 CL300-740 P.S.I @ 100° F
 CL600-1480 P.S.I @ 100° F
 CL800-1975 P.S.I @ 100° F
 CL1500-3705 P.S.I @ 100° F

Main part materials list

NO.	Part name	A105/F6a	LF2/304	F304(L)/304(L)	F316(L)/316(L)	F51/F51
1	Body	A105	LF2	F304(L)	F316(L)	F51
2	Seat	RPTFE & PEEK	RPTFE & PEEK	RPTFE & PEEK	RPTFE & PEEK	RPTFE & PEEK
4	Stem	410	304	304(L)	316(L)	F51
5	Gasket	PTFE	PTFE	PTFE	PTFE	PTFE
8	Pin	25	304	304	304	304
9	Gland	410	304	304(L)	316(L)	F51
14	Flat nut	8	8	8	8M	8M
18	Packing	PTFE	PTFE	PTFE	PTFE	PTFE
37	Bolt	B7	B8	B8	B8M	B8M
38	Nut	2H	8	8	8M	8M
40	Ball	F6	F304	F304(L)	F316(L)	F51
41	O-ring	VITON	VITON	VITON	VITON	VITON
42	Back seat gasket	RPTFE & PEEK	RPTFE & PEEK	RPTFE & PEEK	RPTFE & PEEK	RPTFE & PEEK
43	Wrench	ANSI 1025	ANSI 1025	ANSI 1025	ANSI 1025	ANSI 1025
49	Left bonnet	A105	LF2	F304	F316	F51
50	Right bonnet	A105	LF2	F304	F316	F51
51	Butterfly spring	65Mn	65Mn	304	304	304
52	Elastic washer	65Mn	65Mn	304	304	304
53	Anti-static spring	304	304	304	316L	316L