

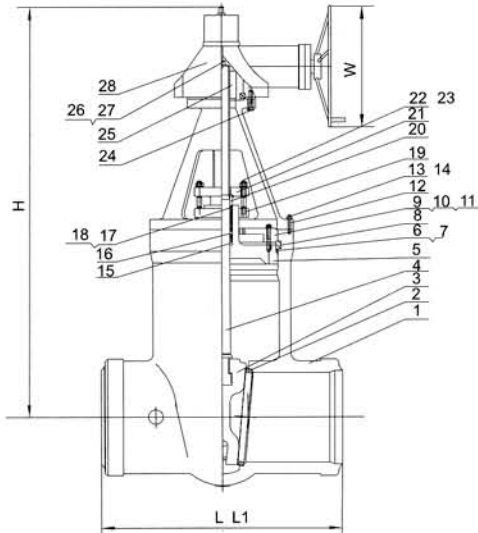

Fumagalli S.p.A
Milano - Roma - Italy

V A L V E S

**ANSI Gate Valves - Pressure Seal
Class 2500**



APPLICABLE STANDARD

Basic Design: ANSI B16.34
Face To Face: ANSI B16.10
End To End: ANSI B16.10;
End Flanges:
2"–24": ANSI B16.5
Welding Ends: ANSI B16.25

BILL OF MATERIALS & PARTS

Item	Part Name
1	Body
2	Seat Ring
3	Flexible Wedge
4	Stem
5	Stuffing Box
6	Sealing Ring
7	Pressure Ring
8	Segment Ring
9	Support Plate
10	Box-Plate Bolt
11	Box-Plate Nut
12	Yoke
13	Box-Plate Bolt
14	Box-Plate Nut
15	Packing Plate
16	Lantern
17	Packing 1
18	Packing 11
19	Gland Flange Seat
20	Gland
21	Gland Flange
22	Gland Eyebolt
23	Gland Eyebolt Nut
24	Yoke Gear Stud
25	Stem Nut

DIMENSIONS AND WEIGHTS (MM)

NOM SIZE	2	3	4	6	8	10	12	14	16
L RF	451	578	673	917	1022	1270	—	—	—
L1 BW	279	368	457	610	762	914	1041	1118	1245
H	610	753	850	1254	1374	1685	1752	1879	1981
W	500	500	600	GO	GO	GO	GO	GO	GO
Wt	88	135	215	550	900	1600	2300	3200	4100