



Fumagalli S.p.A

Milano - Roma - Italy

V A L V E S

**ANSI Gate Valves - Pressure Seal
Class 900**

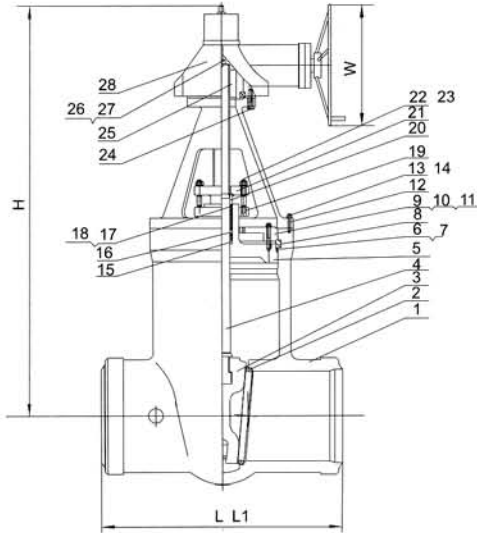

APPLICABLE STANDARD

Basic Design: ANSI B16.34
 Face To Face: ANSI B16.10
 End To End: ANSI B16.10;
 End Flanges:
 2"—24": ANSI B16.5
 26"—32": MSS-SP44
 Welding Ends: ANSI B16.25

BILL OF MATERIALS & PARTS

Item	Part Name
1	Body
2	Seat Ring
3	Flexible Wedge
4	Stem
5	Stuffing Box
6	Sealing Ring
7	Pressure Ring
8	Segment Ring
9	Support Plate
10	Box-Plate Bolt
11	Box-Plate Nut
12	Yoke
13	Box-Plate Bolt
14	Box-Plate Nut
15	Packing Plate
16	Lantern
17	Packing 1
18	Packing 11
19	Gland Flange Seat
20	Gland
21	Gland Flange
22	Gland Eyebolt
23	Gland Eyebolt Nut
24	Yoke Gear Stud
25	Stem Nut

DIMENSIONS AND WEIGHTS (MM)

NOM SIZE	3	4	6	8	10	12	14	16	18	20	24	28	30	32
L	381	457	609	736	838	965	1028	1130	1219	1320	1549	1663	1778	1857
RF														
L1	304	355	508	660	787	914	990	1092	1219	1320	1549	1663	1778	1854
BW														
H	584	711	863	1016	1181	1320	1568	2159	2381	2451	2971	3695	4000	4165
W	355	355	609	609	711	711	863	GO	GO	GO	GO	GO	GO	GO
Wt	95	130	280	460	820	1150	1500	2100	2750	3400	4400	7100	9000	11000